

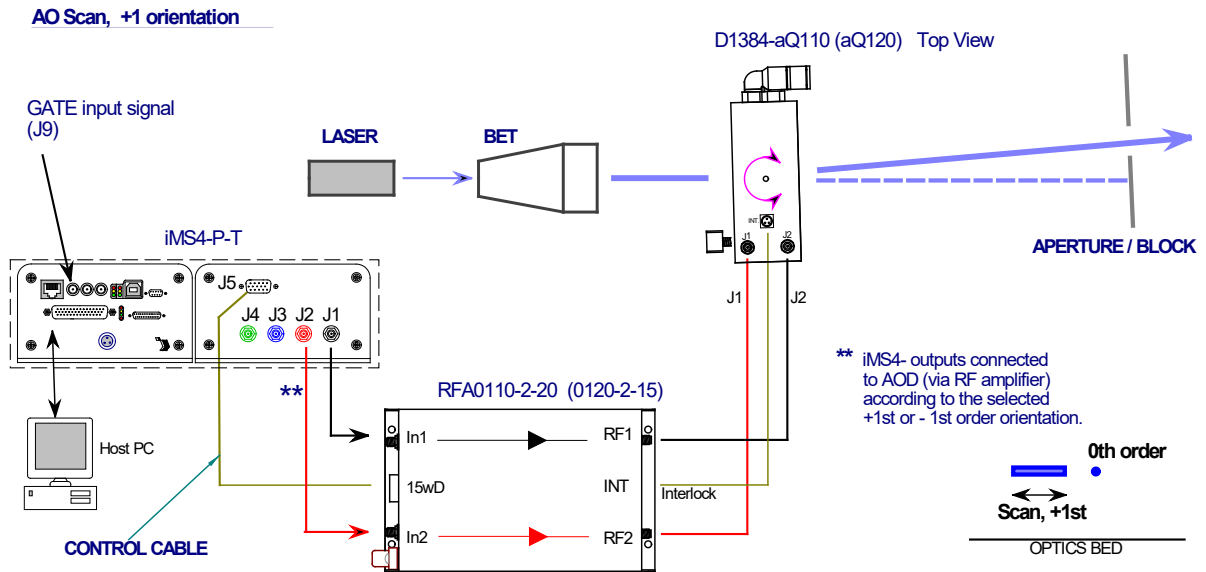

Set-up Guide: iMS4 (Rev-C) and RF amplifier driving a single axis 'beam steered' Acousto-Optic Deflector.

The RF connection order is important. It will define the preferred diffraction order; **+1** first order (= beam away from the RF connector end) or **-1** first order (= beam towards the RF connector end). The following description will use the D1384-aQ120-9 and RFA0120-2-15 amplifier to illustrate the procedure. The same basics apply to all dual RF input AOD models with appropriate RF amplifier(s), e.g. LS110, D1209, D1312, D1319, D1340, D1422 etc.

Connections for +1 order



Connections for -1 order

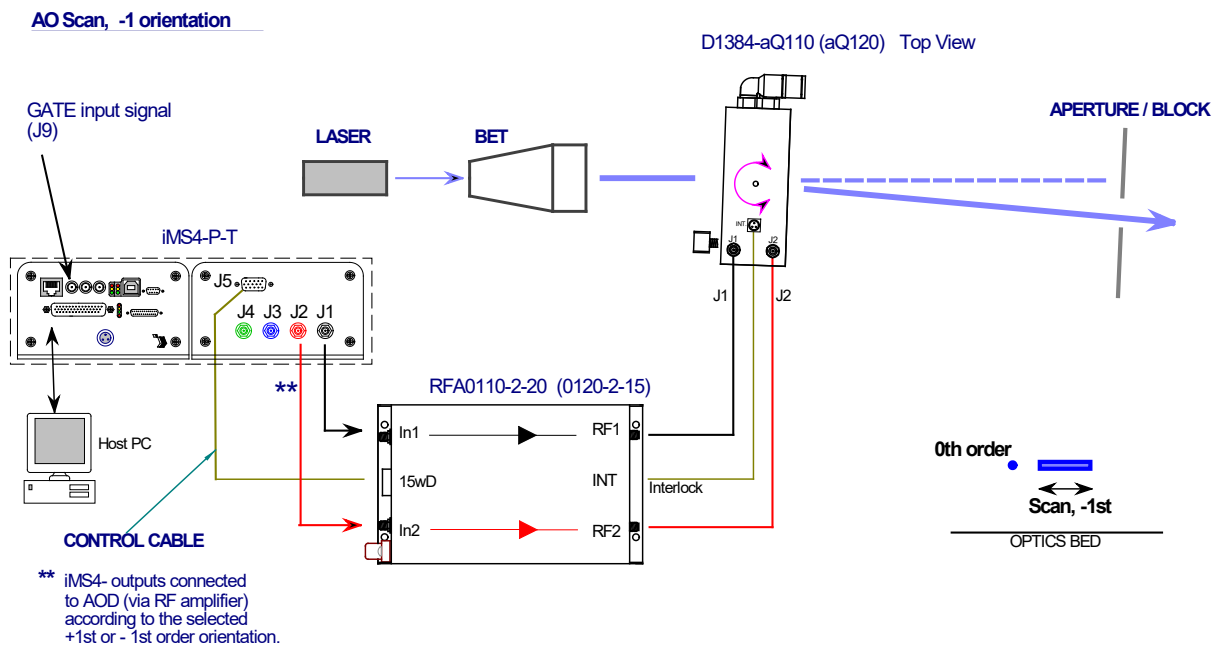

Figure 1: Typical configuration. This orientation uses the -1st, -1st 2D scan.



Procedure

- Step 1: Coolant connections
- Step 2: Electrical connections
- Step 3: Beam alignment
- Step 4: Configuring iMS4-PT (revC)
- Step 5: Set maximum RF power
- Step 6: AOD Bragg angle alignment at centre frequency
- Step 7: Test Scan

Step 1 Coolant connection

Always connect coolant water to both the AOD and RF amplifiers.
 Operate the recirculating chiller at constant temperature between 18 and 25 degC, with a stability better than +/- 0.2 degC. Flow rate of > 1 litres per minute.

Step 2 Electrical connections & LEDs

Connect the iMS4-PT synthesizer and RFA01x0-2 amplifier as shown in Figure 1.

RF signals:

iMS4-P-T			RFA0110-2-20 (RFA0120-2-15)			D1340 / D1384
Phase = 0	J1	⇒	IN1	RF1	⇒	J1
Phase Controlled	J2	⇒	IN2	RF2	⇒	J2
				INT	⇐	INT

Same principles apply to each axis of a Dual Axis AOD.
 A typical XY setup uses a single quad output amplifier e.g. RFA0120-4-15.
 As the coolant for the XY AOD's is normally connected in series, only one of the INT connections needs to be used.



Input control signals

J9 Gate input

Required to enable RF amplifier, active high 5V logic.
 ALWAYS connect the 15way D-type J5 of the iMS4- to the CTRL input of the RF amplifier.

J10 Trigger input

Required if 'External Trigger' is selected in the software.
 Default is a single internal trigger, no repeats.
 This signal initiates the start of an image playback.

J10 Clock input

Required if 'External Clock' is selected in the software.
 Default is Internal clock, 100KHz.
 This signal defines the output rate of the Image points (= rate of change of the AO deflector scan angle)

J5 Amplifier Enable (see page5)

Signal Timing Diagram

Image mode timing with sync outputs. (Latency delays removed for clarity)

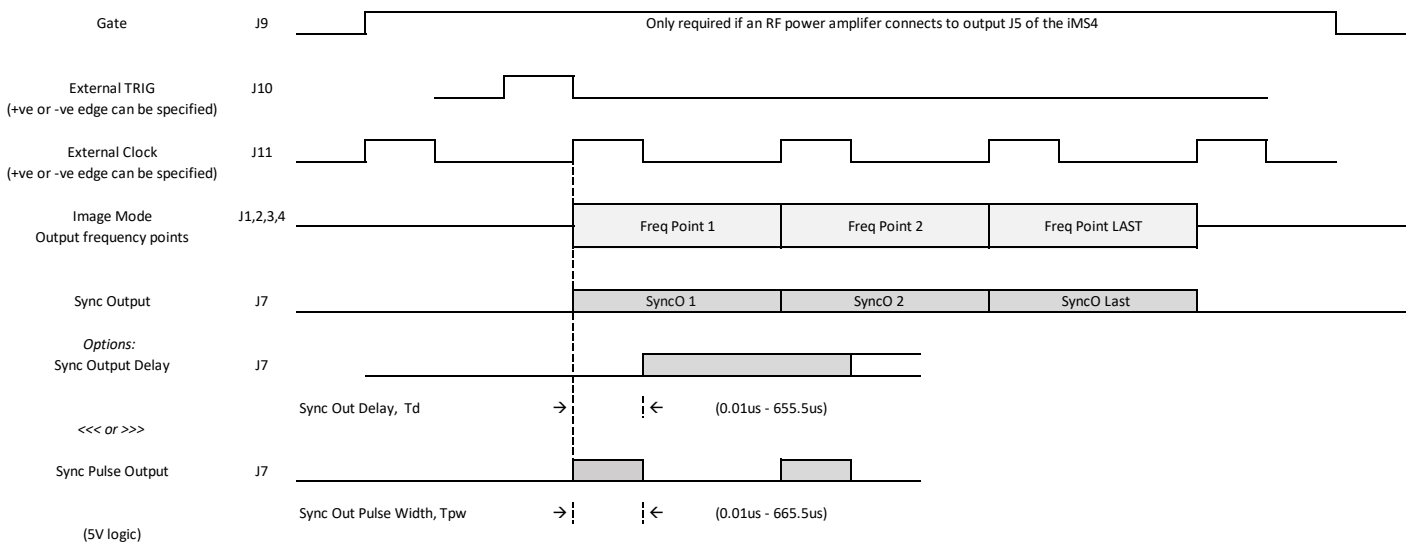



iMS4-PT LED Indicators.

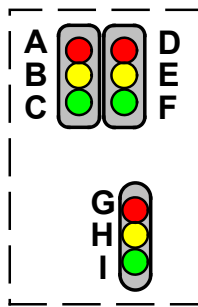

Top Stack, Controller PCB

Ident	LED	Mode	iMS4-P
A	RED (top left)	If illuminated	Not Downloading File
B	Yellow	If illuminated	Downloading File
C	Green	Pulsing	Controller OK
D	RED (top right)	If illuminated	Image output stopped
E	Yellow	If illuminated	Waiting on Trigger
F	Green	If illuminated	Image playing / output active

Lower stack. Synthesizer PCB

Ident	LED	Mode	Stand Alone iMS4-	In combination with PA J5 <u>connected</u>
G	RED (top)	Constant on	DC power On	Thermal Interlock Open (= fault) or GATE input J9 = low/OFF
H	Yellow	Constant on	NA	PA is enabled. Thermal Interlock OK
I	Green	Pulsing	Synthesizer OK	Synthesizer OK

DC power applied, USB communication problem.

If the 6x LED's (A,B,C,D,E,F) are constantly illuminated, then USB communication has not been established. In this case:

- a: Ensure USB driver is loaded.
 - b: Cycle DC power
- and /or
- c: Disconnect - reconnect USB.



Example: operating with internal Image Clock and Trigger, 'Repeat Forever'

- Image Play enabled and running

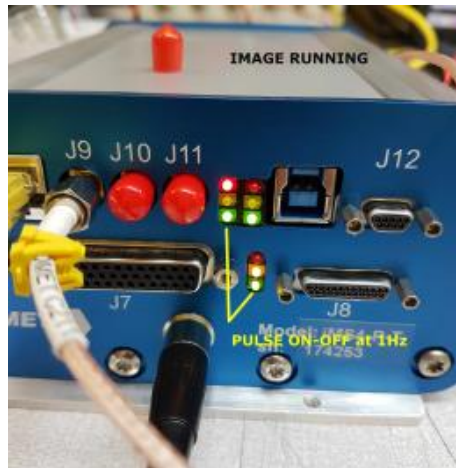

- Image Play stopped correctly

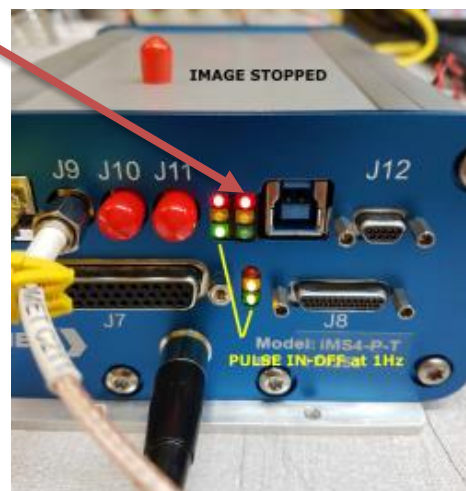

- Fault with RFA amplifier interlock or a low signal / disconnected signal on J9, Gate input



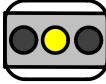

RFA01x0-2 / RFA01x0-4 LED Indicators

- ✓ 24V connected and DC power on
 - ✗ Interlocks not connected
 - ✗ Over temperature fault / Coolant failure
- 

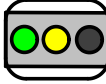
- ✓ 24V connected and DC power on
 - ✓ Interlocks OK
 - ✗ GATE Low, J9 (= RF amp disabled)
- 

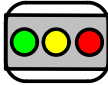
- ✓ 24V connected and DC power on
 - ✓ Interlocks OK
 - ✓ GATE High, J9 (RF enabled)
- 

RFA01x0-2 (-4), 15-way D-type connector

Connection is required to J5, (15way-D) to allow the GATE signal to function correctly. This requires both the **AMPLIFIER ENABLE** software command and a logic high signal on the SMA input J9 of the iMS4.

The control cable connection allows remote enable – disable function, as well as temperature and VSWR diagnostics.

Notes:

The RF outputs can also be temporarily disabled by disconnecting the INT connection at the AOD.

For XY deflectors, the coolant is normally connected in series. In this case is acceptable to use one INT connection only.



Step 3: Beam Alignment

Initial alignment without RF power.

Ensure the laser beam is aligned centrally in the AO active aperture. This alignment is especially important if the beam diameter approaches the active aperture height dimension H

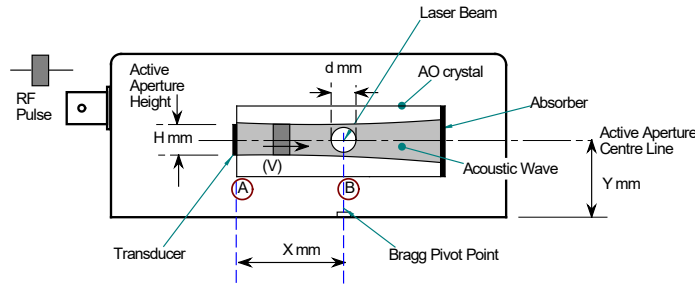

If in doubt, please refer to app note: Optimizing Efficiency .pdf

Step 4: Configuring iMS4-P-T

Quick overview of AO Scanning Theory

Isomet AO deflectors commonly employ acoustic beam steering. This improves the scan uniformity and diffraction efficiency as the frequency is tuned to deflect the laser beam. To achieve this, the RF drive frequency applied at the two AOD inputs (J1, J2) is controlled in phase and amplitude value.

At the centre frequency, the phase difference between the two AOD inputs is zero. At all other frequencies, there is a positive (+ph) or negative phase (-ph) difference.

At any given moment, the frequency and amplitude applied to each AOD has the same value. Only the phase is different between the two inputs of each AOD.

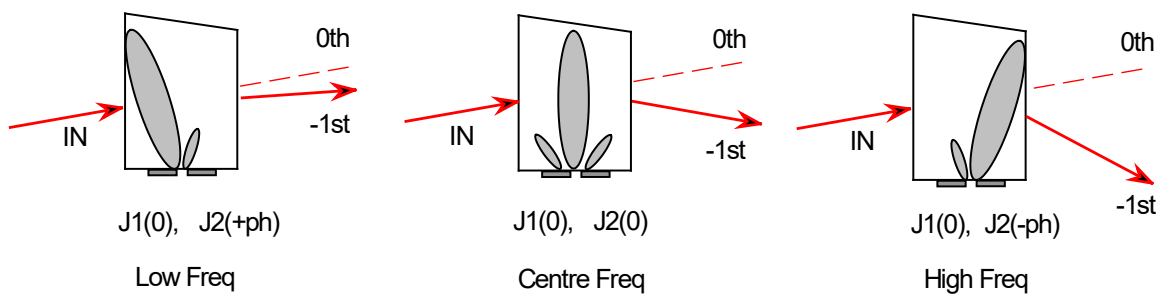

Theoretical phase values are supplied in the default LUT files for the specific AOD and wavelength.



Step 5: Setting the Power Level Wipers

The maximum output power level is set by a combination of the **DDS** and channel **Amplitude** Wipers. We will assume Channel-1 and Channel-2 of the iMS4 are used.

- 1: Set the maximum RF power limit *

Synthesizer Rev-C

Rev-C has independent power level set for **each** channel independently. Select **Signal Path** panel and set the power control wiper values.

DDS Power: 80% **

For AOD connected to Ch1 and Ch2

CH1 Wiper Power: 50% **

CH2 Wiper Power: 50% (must be same as CH1)

CH3 Wiper Power: 0% or OFF (red =EXT)

CH4 Wiper Power: 0% or OFF (red=EXT)

(Ch3 and Ch4 would be used for a dual axis AOD)

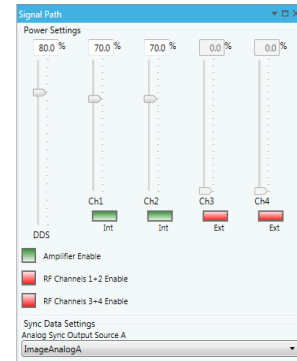

- 2: Enable the RF power amplifier ***.

Click on **Amplifier Enable** button **Green** (On)

RF power will be applied to the AOD, when the *Amplifier Enable* button is active.

*** CAUTION: THERE IS A RISK OF SERIOUS DAMAGE TO THE AO DEVICES IF OPERATED AT EXCESSIVE (CW) RF POWERS.**

** These values will depend on connected power amplifier (PA) and AO device. In this example, W1 level of 50% assumes a ~1m coax cable length from the RF amplifier to AOD. For longer cable lengths, this value will need to be increased. (60% for 4m+) Please contact Isomet, if uncertain.

Recommended values are provided on the specific AOD test data sheet.

*** Will depend on the amplifier model. Some simpler amplifiers do not require this control.



Step 6: Setting BRAGG angle

- 1: Place a detector at first order beam position. See Figure 1
- 2: Select **Calibration panel** tab

iMS4 Rev-C

Slider values apply to all channels simultaneously UNLESS channel *HOLD* button(s) is active.

There is one HOLD button for each channel.
If HOLD the button is active, the channel output is frozen and the output is set to the frequency-amplitude-phase (F-A-P) value at the time the HOLD button was initiated.

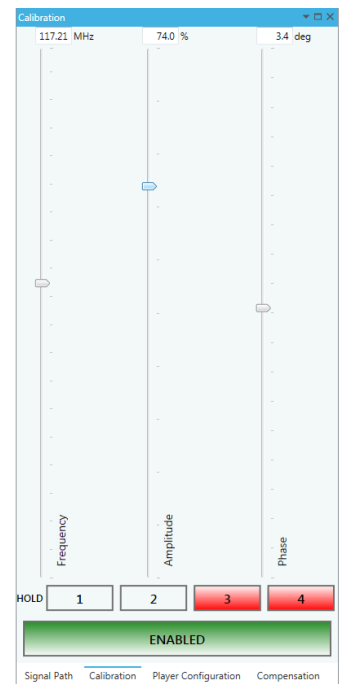

Select Bragg Frequency

Take the model D1384-aQ120, this AOD has a maximum frequency RF bandwidth of 40MHz at a nominal centre frequency $f_c = 120\text{MHz}$.

Note: for optimum efficiency across the full bandwidth, the centre frequency may need to adjusted +/- 10MHz.

Adjust Calibration panel sliders for the Bragg Adjustment.

- 1: Set **Frequency** to f_c . (in this example 120MHz).
- 2: Set **Phase** to Zero. The Phase is always Zero at the Bragg angle.
- 3: Set **Amplitude** to a starting value of 50%.

Tip: Drag the wiper position using a mouse or enter the value directly in the window and click on the wiper button to activate. Wiper position will then update to the frequency value.

- 4: Adjust the AOD Bragg angle to find the peak efficiency.

- 5: Re-adjust the **Amplitude** slider, (Calibration panel) to maximize diffraction efficiency (DE). Peak single axis efficiency is typically in the range of 85-90% and will be recorded on the test data sheet.

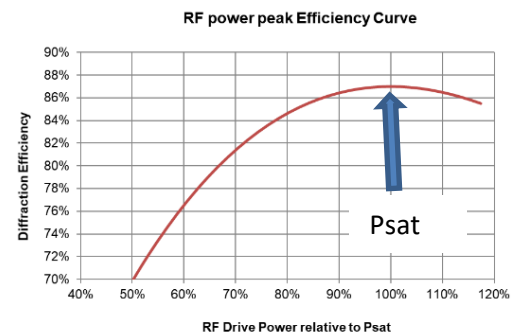



6: Record the peak **DE**, **Amplitude** and **Frequency** values.

7: Secure mechanical Bragg angle adjusters.

Tip: DO NOT overdrive and exceed Psat @ 100%.

It is better to operate at <95% and NOT at 100% of the Psat RF drive level.

As noted from the curve above, a small sacrifice in diffraction efficiency of ~2%. will reduce the RF drive power by 10%. This will help to minimize thermal dissipation in the AOD.

8: **Quartz and Germanium AOD's are polarization sensitive**. A half-wave plate rotates the polarization for the orthogonal axis in an X-Y AOD set. To check the half-wave plate orientation, operate both AOD's at the centre frequency. Optimize Bragg adjustment and then rotate half-wave plate to further peak the combined X-Y efficiency.

Step 7: Test Scan

Create an Image file that generates a line scan over the frequency of interest.

To check general alignment and gauge the “health” of the AOD, it is sufficient to operate with the default LUT calibration file supplied by Isomet. This will contain theoretical Phase values and a basic Amplitude compensation values.

Typically, the diffraction efficiency sweep will take a “humped” profile, depending on factors such as cable length and RF power. The average efficiency of this test will be indicative of performance. In situations where low efficiencies are recorded, this technique may help to narrow down any issues.

e.g. single axis scan, non-optimized amplitude, theoretical phase.

The DDS power level set at ~40% to reduce the overall AOD efficiency and illustrate the expected efficiency sweep applying non-optimised compensation table.

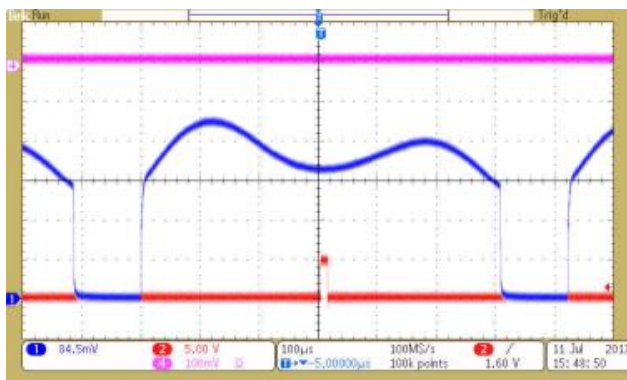

Sweep response 100-140MHz.
 Trace 1 (blue) = -1st order diffraction efficiency
 Trace 4 (magenta) = 100% efficiency level
 Trace 2 (red) = 0% efficiency level,
 and sync out pulse @120MHz

Half power sweep with basic default LUT



With amplitude and phase calibration and careful adjustment of the RF power, the efficiency and uniformity is improved. (refer iMS4 Compensation LUT Guide).

Typical single axis sweep with optimized LUT compensation file:
D1384-aQ120-9 (374nm)

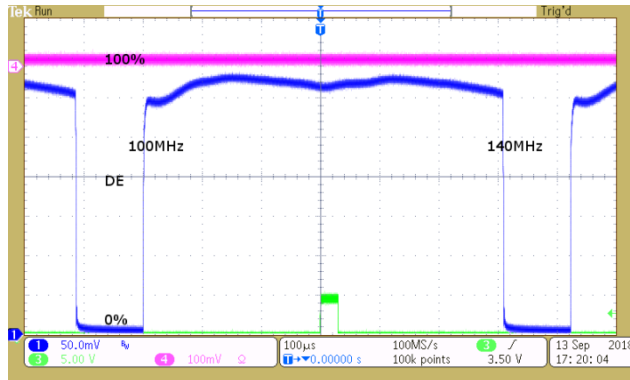

Zero order Measurement

An alternative to using a detector on the scanned deflected beam is to place the detector on the static Zero order beam and measure the power reduction.

Typical Zero order kick-out. 0% = no diffraction

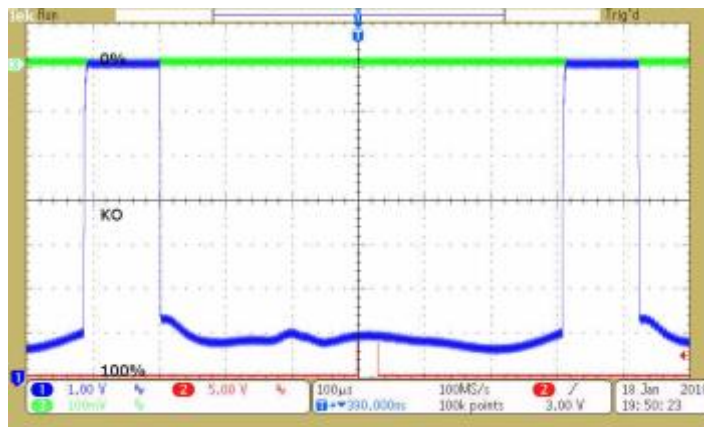

Tip: A word of caution.

*Low power in the zero order does not always mean high power in the desired first order.
e.g. Excess RF power will cause diffraction into unwanted orders.*



Laser Beam Scanning

Users may be familiar with Galvo mirror scanners.

There are significant differences to consider compared to AO scanning.

An appreciation of these will aid understanding of the iMS4 features, controls, and programming.

Galvo.

- Large scan angles, moderate positional accuracy, degrades at speed.
- Mechanical movement.
- Mass limits scan speed and random positioning.
- Sharp and accurate changes in direction are difficult.
- **Feedback calibration required for angular errors and position repeatability.**
- Uniform laser power across scan range. i.e. it's a mirror !

AO Deflector

- Small scan angles, extremely high positional accuracy, not speed dependent.
- Solid state. Random positioning is inherent and simple.
- Acoustic velocity and beam diameter define the maximum scan speed.
- RF drive frequency defines the angle. Highly stable with a synthesiser source.
- No limits to scan direction changes. e.g. square holes with a 2D AO scanner are relatively simple.
- **Compensation-calibration required only for laser power uniformity across the scan.**
- Stable, precise and repeatable angle control across the full scan range.

In summary:

Galvo = Calibration for angle accuracy, power uniformity inherently high

AOD = Calibration for power uniformity, angle accuracy inherently high